



ST60 High Temp: 300°C & 225°C Options

Silicon Based Thermopile Detector

Features: A specially constructed MEMS based thermopile that will withstand operating temperatures of 300°C with Silicon window, and 225°C with coated windows*. The reduced height (.090" tall cover) helps minimize the thermal path and gradient potential of the package.

Options:

- 1) 225°C operation with performance enhancing energy absorber on active area (limited exposure up to 300°C). Extended 300°C operation without performance enhancing absorber. See specs below.
- 2) ST60R version offers a low-cost (20% tolerance) poly-silicon resistor to be used as a PTC thermistor up to 300°C. An internal NTC chip thermistor option is available for operation to 225°C.
- 3) Package hole size options can customize the active area/FoV per specific application(s), data below is based on .047" dia. opening in cap.
- 4) Internal compensating die option available for additional gradient compensation.
- 5) Option with Si+DLC window stable to 300°C. *Common physical/spectral properties of window coatings limit their operational temp to ~225°C.

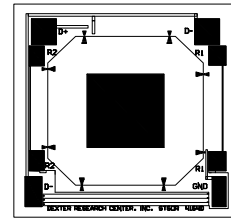

Detector die layout



ST60 High Temperature

2017 Release

Technical Specifications

Specifications apply at 23°C with DLC coated Si window and nitrogen encapsulating gas. [brackets = data for 300°C option as of ~6/1/18]

Parameter	Min	Typical	Max	Symbol	Units	Comments
Active Area size		.61 x .61		AA	mm	Hot junction size, per element.
Element Area		.37		A	mm ²	Per detector element
Number of Junctions		80				Per detector element.
Number of Channels		1				Per detector package.
Output Voltage		50 [22]		V _s	μV	DC, H=330μW/cm ² (3).
Signal-to-Noise Ratio		1597 [702]		SNR	√Hz	DC, SNR=V _s /V _n
Responsivity		40.8 [17.9]		ℳ	V/W	DC, ℳ=V _s /HA (2)
Resistance	45	60	70	R	kΩ	Per detector element
Temperature Coefficient of ℳ		-.04			%/°C	Best linear fit, 0° to 85°C (1)
Temperature Coefficient of R		.11			%/°C	Best fit, 0° to 85°C (1)
Noise Voltage		31.3		V _n	nV/√Hz	V _n ² =4kTR
Noise Equivalent Power		.77 [.18]		NEP	nW/√Hz	DC, NEP= V _n HA/V _s (2)
Detectivity		.79 [.35]		D*	10 ⁸ cm√Hz/W	DC, D*=V _s /V _n H√A (2)
Time Constant		18 [<18]		τ	ms	Chopped, -3dB point (1)
Field of View		14°/93° [32°/82°]		FOV	Degrees	See Assembly Drawings for FOV Description.
Package Type		TO-5				Performance stated is with package hole size of Ø.047"
Operating Temperature	0	225°C [300C]		T _a	°C	With durations to 315°C (tbd)
ST60R Thermistor Option	24	30	36	R _T	kΩ	Optional PTC Poly-Silicon resistor on detector die.
ST60R Thermistor Temperature Coefficient of R	.107	.11	.113		%/°C	ΔR/(RΔT), Best fit, 0° to 85°C (1)

General Specifications: Linear signal output from 10⁻⁶ to 0.1W/cm². Maximum incident radiance 0.1W/cm², damage threshold ≥ .5W/cm²

Notes: (1) Parameter is not 100% tested. 90% of all units meet these specifications. (2) A is detector area in cm². (3) Test Conditions: 500K Blackbody source; Detector active surface 10cm from 0.6513cm Diameter Blackbody Aperture.

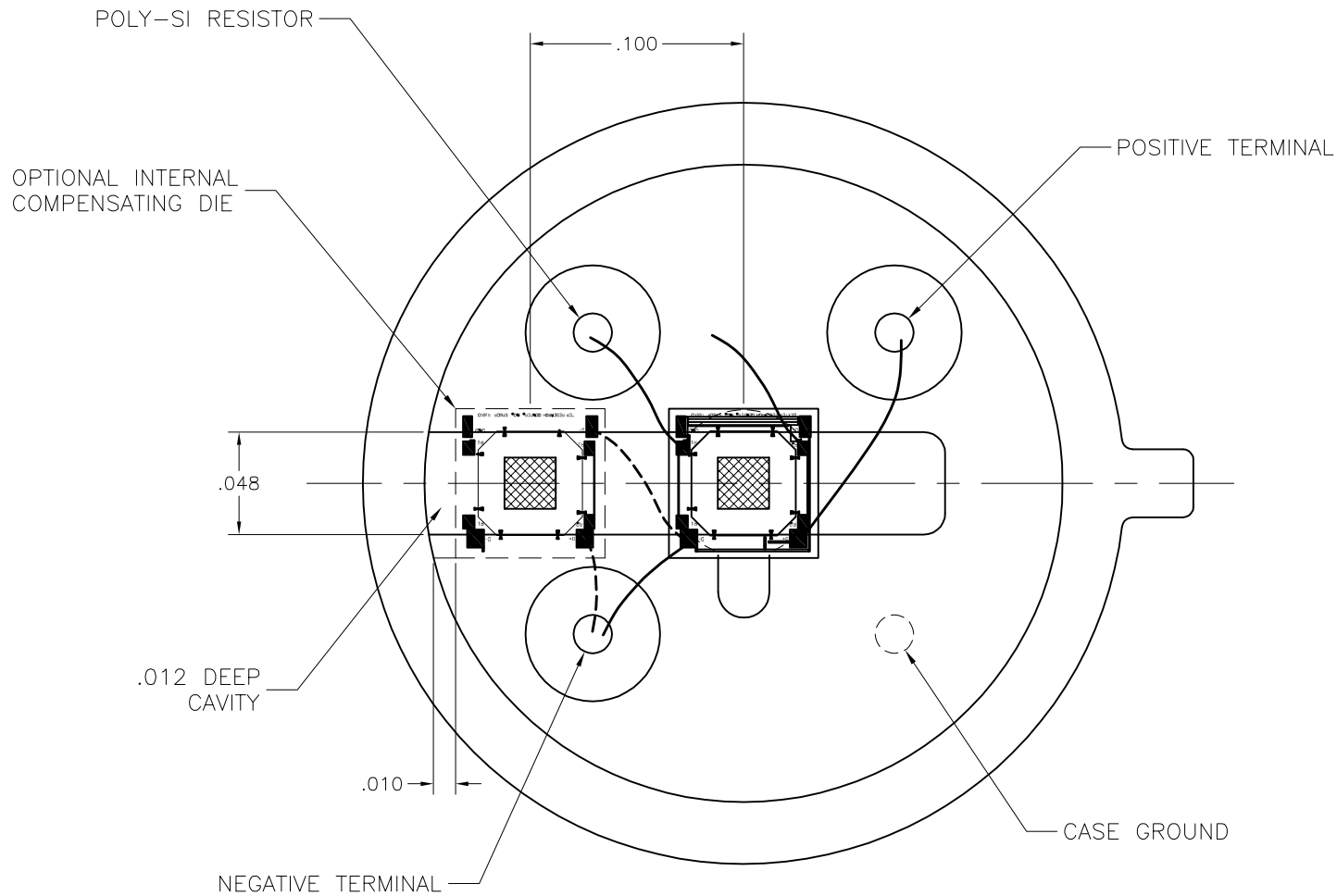

UNLESS OTHERWISE SPECIFIED, ALL DIMENSIONS ARE IN INCHES.
 TOLERANCES ARE:
 FRACTIONS DECIMALS ANGLES
 ± .XX ± .01 ±
 ± .XXX ± .005 ±

APPROVALS	DATE
DRAWN: DLJ	4/27/18
CHECKED:	
ENGINEERED:	
APPROVED:	

DEXTER RESEARCH CENTER, Inc. 7300 Huron River Dr., Dexter, MI 48130, ph. 734-426-3921 fax 734-426-5090			
ASSEMBLY, ST60R, ST60R COMPENSATED HIGH TEMP, TOP VIEW			
SIZE: A	SCALE: 12" = 1"	DWG. NO. 1427.1	REV. NC
DRC PART NO.		MATERIAL:	PAGE: 1 OF 2
		FINISH:	

SILICON WINDOW
W/ DLC COATING
.177 SQ x .020

OPTIONAL INTERNAL
COMPENSATING DIE

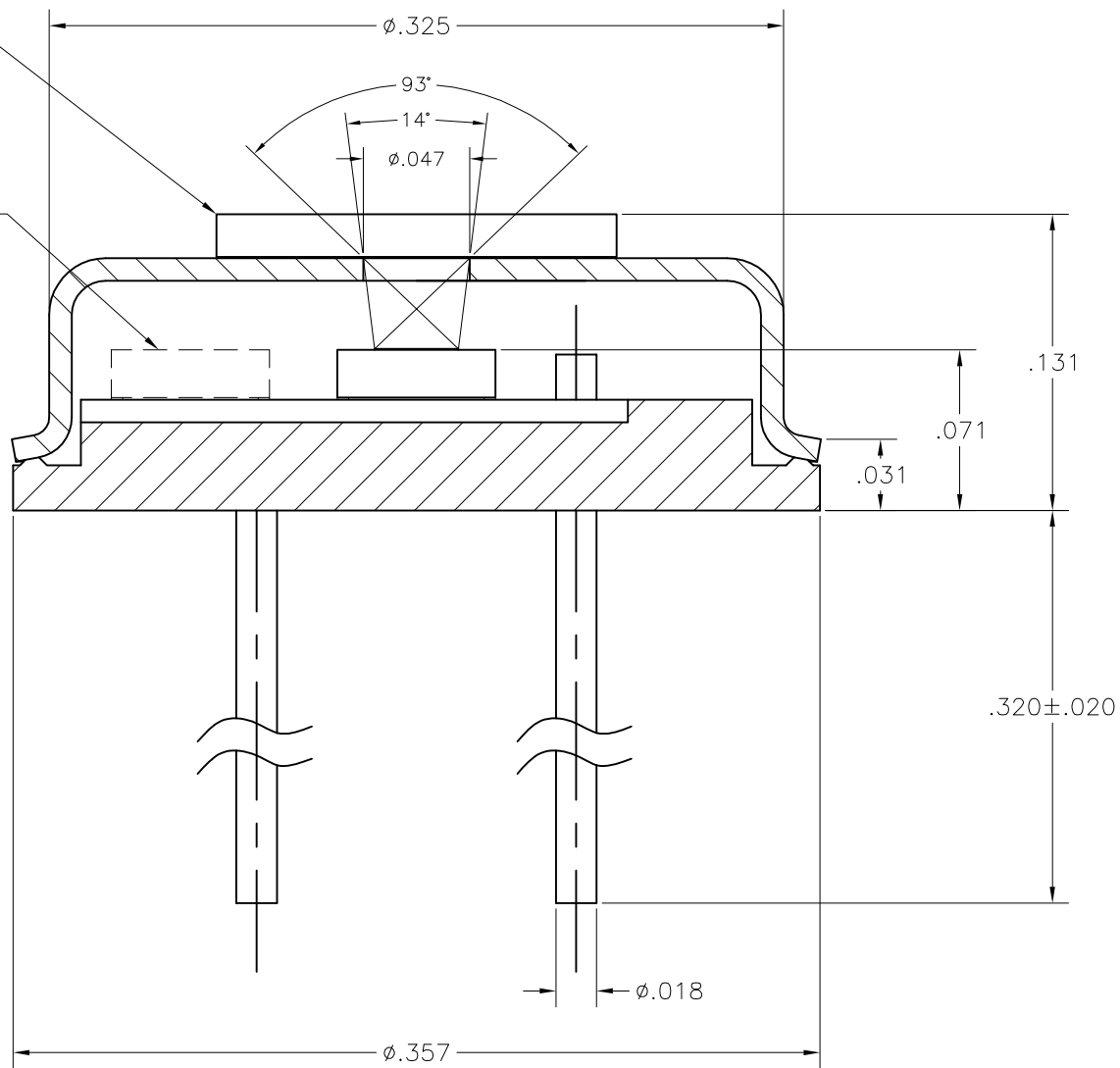

- NOTES:
- FOV = 14°/93° WHEN ADDITIONAL ENERGY ABSORBER IS USED (225°C OPERATION, W/LIMITED EXPOSURE TO TEMPS ABOVE 225°C)
 - FOV = 32°/82° WHEN ADDITIONAL ENERGY ABSORBER IS NOT USED (EXTENDED 300°C OPERATION)

UNLESS OTHERWISE SPECIFIED, ALL DIMENSIONS ARE IN INCHES.		
TOLERANCES ARE:		
FRACTIONS	DECIMALS	ANGLES
±	.XX ± .01 .XXX ± .005	±
APPROVALS	DATE	
DRAWN:	DLJ	6/1/18
CHECKED:		
ENGINEERED:		
APPROVED:		

DEXTER RESEARCH CENTER, Inc.

7300 Huron River Dr., Dexter, MI 48130, ph. 734-426-3921 fax 734-426-5090

ASSEMBLY, ST60R, ST60R COMPENSATED
HIGH TEMP, CROSS SECTION

SIZE:	SCALE:	DWG. NO.	REV.	PAGE:
A	12" = 1"	1427.2	NC	2 OF 2
DRC PART NO.		MATERIAL:	FINISH:	